

HELIX[®] GRINDER

SERVICE MANUAL



Read Manual Before Servicing Machine

Table of Contents

Table of Contents	3
Features and Specifications	4
Safety	5
General Rules for Safe Operation	5
Grinder Safety Guidelines.....	6
Electrical Practices	7
Troubleshooting Guide	9
Maintenance	10
General Maintenance	10
Removing Tooling Assembly.....	10
Replacing Nylon Clutch	10
Replacing Satellite Bearing Assemblies	11
Replacing Morflex Couplers.....	11
Replacing Motor Brushes	12
Light	13
Accessing Electrical Components	13
Parts List and Diagrams	14
Overall Machine.....	14
Base Assembly	15
402757 Tooling Assembly	16
403231 Skirt Assembly	17
Motor.....	18
Lower Handle Assembly	19
Upper Handle Assembly	20
Handle Assembly (International Only)	21
Control Panel	22
Labels	24
Wiring Diagrams	25
Warranty	29

Features and Specifications

Product Specifications

Width	Length	Height	Weight	HP	Disk Size
Max: 17.5" (44.5 cm) Min: 16.9" (42.9 cm)	Max: 47" (119.4 cm) Min: 27.9" (70.9 cm)	Max: 47.6" (120.9 cm) Min: 29.4" (74.7 cm)	206 lbs (93.4 kg) with tooling assembly 180 lbs (81.6 kg) without tooling assembly	1.5	16" (40.6 cm)

Machine Variants

Region	Serial Number	Input Power	Amps (Full Load)	Motor RPM (High/Low Speed)	Tooling Assembly RPM (High/Low Speed)
Domestic (North America)	HELIX-10XXXX	120V / 60 Hz	15A	3339 / 1878	304 / 171
	HELIX-12XXXX	120V / 60 Hz	15A	3339 / 1878	304 / 171
	HELIX-23XXXX	120V / 60 Hz	15A	3339 / 1878	304 / 171
International	HELIX-11XXXX	230V / 50 Hz	8A	3200 / 1800	291 / 164
	HELIX-13XXXX	230V / 50 Hz	8A	3200 / 1800	291 / 164
	HELIX-15XXXX	230V / 50 Hz	8A	3200 / 1800	291 / 164
	HELIX-20XXXX	110V / 50 Hz	15A	3061 / 1722	278 / 157
	HELIX-26XXXX	230V / 50 Hz	8A	3200 / 1800	291 / 164
	HELIX-27XXXX	230V / 50 Hz	8A	3200 / 1800	291 / 164
	HELIX-28XXXX	100V / 50/60 Hz	15A	2783	253

GENERAL RULES FOR SAFE OPERATION

Before use, anyone operating or performing maintenance on this equipment must read and understand this manual, as well as any labels packaged with or attached to the machine and its components. Read the manual carefully to learn equipment applications and limitations, as well as potential hazards associated with this type of equipment. Keep manual near machine at all times. If your manual is lost or damaged, contact National Flooring Equipment (NFE) for a replacement.

Personal

Dress properly and use safety gear.

Do not wear loose clothing; it may be caught in moving parts. Anyone in the work area must wear safety goggles or glasses and hearing protection. Wear a dust mask for dusty operations. Hard hats, face shields, safety shoes, etc. should be worn when specified or necessary.

Maintain control; stay alert.

Keep proper footing and balance, and maintain a firm grip. Observe surroundings at all times. Do not use when tired, distracted, or under the influence of drugs, alcohol, or any medication that may cause decreased control.

Keep hands away from all moving parts and tooling.

Wear gloves when changing tooling. Remove tooling when machine is not in use and/or lower cutting head to the floor.

Do not force equipment.

Equipment will perform best at the rate for which it was designed. Excessive force only causes operator fatigue, increased wear, and reduced control.

Environment

Avoid use in dangerous environments.

Do not use in rain, damp or wet locations, or in the presence of explosive atmospheres (gaseous fumes, dust, or flammable materials). Remove materials or debris that may be ignited by sparks. Keep work area tidy and well-lit - a cluttered or dark work area may lead to accidents. Extreme heat or cold may affect performance.

Protect others in the work area and be aware of surroundings.

Provide barriers or shields as needed to protect others from debris and machine operation. Children and other bystanders should be kept at a safe distance from the work area to avoid distracting the operator and/or coming into contact with the machine. Operator should be aware of who is around them and their proximity. Support personnel should never stand next to, in front of, or behind the machine while the machine is running. Operator should look behind them before backing up.

Guard against electric shock.

Ensure that machine is connected to a properly grounded outlet. Prevent bodily contact with grounded surfaces, e.g. pipes, radiators, ranges, and refrigerators. When scoring or making cuts, always check the work area for hidden wires or pipes.

Maintenance & Repairs

Begin maintenance work only when the machine is shut down, unplugged, and cooled down.

Use proper cleaning agents.

Ensure that all cleaning rags are fiber-free; do not use any aggressive cleaning products.

Schedule regular maintenance check-ups.

Ensure machine is properly cleaned and serviced. Remove all traces of oil, combustible fuel, or cleaning fluids from the machine and its connections and fittings. Retighten all loose fittings found during maintenance and repair work. Loose or damaged parts should be replaced immediately; use only NFE parts.

Do not weld or flame-cut on the machine during repairs, or make changes to machine without authorization from NFE.

Equipment

Use proper parts and accessories.

Only use NFE-approved or recommended parts and accessories. Using any that are not recommended may be hazardous.

Ensure accessories are properly installed and maintained.

Do not permanently remove a guard or other safety device when installing an accessory or attachment.

Inspect for damaged parts.

Check for misalignment, binding of moving parts, loose fasteners, improper mounting, broken parts, and any other conditions that may affect operation. If abnormal noise or vibration occurs, turn the machine off immediately. Do not use damaged equipment until repaired. Do not use if power switch does not turn machine on and off. For all repairs, insist on only identical NFE replacement parts.

Maintain equipment and labels.

Keep handles dry, clean, and free from oil and grease. Keep cutting edges sharp and clean. Follow instructions for lubricating and changing accessories. Motor and switches should be completely enclosed at all times with no exposed wiring. Inspect cord regularly. Labels carry important information; if unreadable or missing, contact NFE for a free replacement.

Avoid accidental starting; store idle equipment.

When not in use, ensure that the machine is unplugged; do not turn on before plugging in. Store in a dry, secured place. Remove tooling when storing, and keep away from children.

Safety

GRINDER SAFETY GUIDELINES

Before use, anyone operating this equipment must read and understand these safety instructions.

Grinding

Beware of hidden obtrusions.

Watch out for hidden dangers and protrusions in flooring. Do not use on largely uneven surfaces.

Avoid contact with hot tooling and shroud.

Do not touch the tooling or shroud without proper hand protection. Both become hot during operation and remain hot after stopping the machine.

Use correct tooling and accessories.

Provide barriers or shields as needed to protect others from debris.

Use for correct applications.

Do not force equipment to do heavier duty work than it was made for.

Do not block the machine's air flow.

Blocking ventilation slots or air flow will result in damage to the machine. Leave space for air to flow freely during operation.

Use safety key and wrist wrap during operation.

Loss of control of the grinder could cause damage, injury, or death.

Dust Collection

Use with appropriate dust collecting system.

Do not operate machine designed for use with a dust collector without the dust collector. Ensure dust collector is on and operating properly while grinding.

Use with appropriate dust collection hose.

Do not operate the machine without the hose securely attached to the inlet of the dust collector and the outlet of the grinder. In order to maintain system efficiency, do not use a damaged hose.

Dispose of collected waste.

Do not leave the dust collector bag full of waste. Handle and dispose of bag and waste in accordance with all applicable local, state, and federal regulations. Dispose of waste prior to transport.

Battery (Propane Machines Only)

Remove personal metal items when working with battery.

A battery can produce a short circuit current sufficient enough to weld metal objects, causing severe burns. Be careful to not drop metal tools on the battery, as a spark or short circuit could cause an explosion.

Never smoke or allow a spark or flame near the battery.



WARNING: BE CAUTIOUS WHEN WORKING WITH BATTERY. IF ELECTROLYTIC ACID GETS IN THE EYES, IMMEDIATELY FLUSH OUT WITH COLD, FRESH WATER FOR AT LEAST 10 MINUTES AND GET MEDICAL HELP.

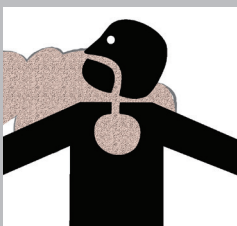

WARNING: GRINDING/CUTTING/DRILLING OF MASONRY, CONCRETE, METAL AND OTHER MATERIALS CAN GENERATE DUST, MISTS AND FUMES CONTAINING CHEMICALS KNOWN TO CAUSE SERIOUS FATAL INJURY OR ILLNESS, SUCH AS RESPIRATORY DISEASE, CANCER, BIRTH DEFECTS OR OTHER REPRODUCTIVE HARM. IF YOU ARE UNFAMILIAR WITH THE RISKS ASSOCIATED WITH THE PARTICULAR MATERIAL BEING CUT, REVIEW THE MATERIAL SAFETY DATA SHEET AND/OR CONSULT YOU EMPLOYER, THE MATERIAL MANUFACTURER/SUPPLIER, GOVERNMENTAL AGENCIES SUCH AS OSHA AND NIOSH AND OTHER AUTHORITIES ON HAZARDOUS MATERIALS. CALIFORNIA AND SOME OTHER AUTHORITIES, FOR INSTANCE, HAVE PUBLISHED LISTS OF SUBSTANCES KNOWN TO CAUSE CANCER, REPRODUCTIVE TOXICITY, OR OTHER HARMFUL EFFECTS. CONTROL DUST, MIST AND FUMES AT THE SOURCE WHERE POSSIBLE. IN THIS REGARD USE GOOD WORK PRACTICES AND FOLLOW THE RECOMMENDATIONS OF THE MANUFACTURER/SUPPLIER, OSHA/NIOSH, AND OCCUPATIONAL AND TRADE ASSOCIATIONS. WHEN THE HAZARDS FROM INHALATION OF DUST, MISTS AND FUMES CANNOT BE ELIMINATED, THE OPERATOR AND ANY BYSTANDERS SHOULD ALWAYS WEAR A RESPIRATOR APPROVED BY OSHA/MSHA FOR THE MATERIAL BEING CUT.

ELECTRICAL PRACTICES



WARNING: ELECTRICAL CORDS CAN BE HAZARDOUS. MISUSE CAN RESULT IN FIRE OR DEATH BY ELECTRICAL SHOCK. READ CAREFULLY AND FOLLOW ALL DIRECTIONS.



CAUTION: ALWAYS FOLLOW APPLICABLE ELECTRICAL CODES, STANDARDS AND/OR REGULATIONS. CONSULT YOUR LOCAL ELECTRICAL AUTHORITY OR A LICENSED ELECTRICIAN BEFORE ATTEMPTING TO MODIFY AN ELECTRICAL INSTALLATION. ENSURE THAT CIRCUIT AND GROUND FAULT PROTECTION DEVICES AND ALL OTHER ELECTRICAL SAFETY EQUIPMENT ARE FUNCTIONING PROPERLY.

Extension Cord Requirements

- Ensure the cord type is suitable for the application and location. If you are unsure about your cord type, consult a qualified electrical professional or electrician.
- Ground your equipment. The equipment must be plugged into an appropriate outlet, one which is properly installed and grounded in accordance with all codes and ordinances. Do NOT modify the plug provided with the equipment. Never remove the grounding prong from the plug.
- Do not remove, bend or modify any metal prongs or pins of the plug. Modifications to power cords and/or plugs may result injury and/or equipment damage.
- FULLY INSERT plug into outlet.
- Do not use excessive force to make connections.
- Never unplug by pulling the cord from the outlet. Pull plug rather than cord to reduce the risk of damage.
- Regularly examine your extension cord and ensure it is in good electrical condition. Never use a damaged cord—either replace it or have it repaired by a qualified person.
- Protect your extension cords from sharp objects, excessive heat and damp or wet areas. Keep the cord away from oil, cutting edges and moving parts.
- Do not drive, drag or place objects over cord.
- Avoid overheating. Uncoil cord and do not cover it with any material.
- Avoid accidental starting. Be sure equipment is turned off before plugging in. Do not use equipment if the power switch does not turn the equipment on and off.
- Make sure equipment is not running before disconnecting cord.
- Unplug equipment. When not in use and before changing accessories or performing maintenance, unplug the machine.

Extension Cord Selection

All cords should be sized appropriately to reduce the risk of damage, fire or reduced performance. Reference the table in this section for cord sizes.

Safety

ELECTRICAL PRACTICES—CONTINUED

How to Use This Table

1. Determine your supply voltage.
2. Determine the total length of your cord including all extension cords.
3. Determine the maximum amp draw for your machine.
4. Trace your voltage across the top of the table to the first length that is greater than or equal to your cord length.
5. Follow the column down to the first row that contains a maximum amp draw greater than or equal to yours.
6. This cell contains the minimum wire size for your application.

Example

Application: Max Amps = 11A, Length = 40ft, Voltage = 120V

Solution: 40ft is between the 25ft and 50ft columns, so the larger of the two columns is chosen. Likewise, 11A is between the 10A and 12A rows, so the larger of the two rows is chosen. 14 AWG (2.5mm²) is the minimum wire size for this example.

Single Phase Equipment				
Max Length	120V Supply	25ft (7.5m)	50ft (15m)	75ft (22.5m)
	230V Supply	50ft (15m)	100ft (30m)	150ft (45m)
Max Amps		Minimum Wire Size		
8	16 AWG (1.5mm ²)	16 AWG (1.5mm ²)	16 AWG (1.5mm ²)	16 AWG (1.5mm ²)
10	16 AWG (1.5mm ²)	16 AWG (1.5mm ²)	16 AWG (1.5mm ²)	16 AWG (1.5mm ²)
12	14 AWG (2.5mm ²)	14 AWG (2.5mm ²)	14 AWG (2.5mm ²)	14 AWG (2.5mm ²)
14	14 AWG (2.5mm ²)	14 AWG (2.5mm ²)	14 AWG (2.5mm ²)	14 AWG (2.5mm ²)

Extension Cord Sizes

Single Phase Equipment							
Max Length	120V Supply	25ft (7.5m)	50ft (15m)	75ft (25m)	100ft (30m)	150ft (45m)	200ft (60m)
	230V Supply	50ft (15m)	100ft (30m)	150ft (45m)	200ft (60m)	300ft (90m)	400ft (120m)
Max Amps		Minimum Wire Size					
8	16 AWG (1.5mm ²)	16 AWG (1.5mm ²)	16 AWG (1.5mm ²)	16 AWG (1.5mm ²)	16 AWG (1.5mm ²)	14 AWG (2.5mm ²)	14 AWG (2.5mm ²)
10	16 AWG (1.5mm ²)	16 AWG (1.5mm ²)	16 AWG (1.5mm ²)	16 AWG (1.5mm ²)	16 AWG (1.5mm ²)	14 AWG (2.5mm ²)	12 AWG (4mm ²)
12	14 AWG (2.5mm ²)	14 AWG (2.5mm ²)	14 AWG (2.5mm ²)	14 AWG (2.5mm ²)	14 AWG (2.5mm ²)	12 AWG (4mm ²)	12 AWG (4mm ²)
14	14 AWG (2.5mm ²)	14 AWG (2.5mm ²)	14 AWG (2.5mm ²)	14 AWG (2.5mm ²)	14 AWG (2.5mm ²)	12 AWG (4mm ²)	10 AWG (6mm ²)
16	14 AWG (2.5mm ²)	14 AWG (2.5mm ²)	14 AWG (2.5mm ²)	14 AWG (2.5mm ²)	14 AWG (2.5mm ²)	12 AWG (4mm ²)	10 AWG (6mm ²)
18	14 AWG (2.5mm ²)	14 AWG (2.5mm ²)	14 AWG (2.5mm ²)	12 AWG (4mm ²)	12 AWG (4mm ²)	12 AWG (4mm ²)	10 AWG (6mm ²)
20	12 AWG (4mm ²)	12 AWG (4mm ²)	12 AWG (4mm ²)	12 AWG (4mm ²)	12 AWG (4mm ²)	10 AWG (6mm ²)	10 AWG (6mm ²)
25	12 AWG (4mm ²)	12 AWG (4mm ²)	12 AWG (4mm ²)	12 AWG (4mm ²)	12 AWG (4mm ²)	10 AWG (6mm ²)	8 AWG (10mm ²)
30	10 AWG (6mm ²)	10 AWG (6mm ²)	10 AWG (6mm ²)	10 AWG (6mm ²)	10 AWG (6mm ²)	8 AWG (10mm ²)	8 AWG (10mm ²)

Note: The table is based on a <10% voltage loss, data from the U.S. National Electrical Code Tables 400.5(A) & 400.5(B) and typical resistances for copper wire.

Troubleshooting Guide

Problem	Solution
Machine is hard to handle	Change to a less aggressive tooling.
	Remove weights.
	Change handle position to gain better leverage.
Debris is coming out from the bottom of the machine	Check dust skirt to make sure it is mounted and secured properly. The bottom edge of the skirt should be touching the floor.
	Remove vacuum hose and check to see if port is plugged.
	Ensure dust collector is working properly.
Blows fuses or circuit breakers	Ensure use of proper extension cord. See Safety section.
	Move to a different outlet on an independent circuit.
	Change to a less aggressive tooling.
	Remove weights.
Motor will not run	Ensure machine is connected to power.
	Check if light on motor is on; if so, change brushes.
	Ensure safety key is properly inserted.
	Ensure handle and motor cords are connected.
Noisy or excessive vibration	Change to a different tooling specific for the job.
	Ensure tooling is properly installed.
Light does not turn on	Ensure light is plugged in (just above where the light is located).
Satellites do not rotate freely	Clean satellite bearing bores and satellite shafts.

Note: For further assistance, contact NFE customer service.

Maintenance



FIG. 1



WARNING: BEFORE STARTING REPAIR OR MAINTENANCE WORK, ALWAYS TURN OFF THE MACHINE, WAIT FOR STANDSTILL OF ALL DEVICES, PULL OUT THE MAIN PLUGS AND REMOVE THE SAFETY KEY TO SECURE THE MACHINE AGAINST UNINTENDED STARTUP.

GENERAL MAINTENANCE

A well-maintained machine is a productive machine. If not properly maintained, it could be unsafe or break down. Schedule regular maintenance check-ups to ensure efficient performance and a long life. The following maintenance should be performed by an NFE service center or dealer:

- Mechanical inspection and cleaning (bearings, nuts, bolts, housing, labels, etc.).
- Replacing worn or damaged parts (switches, guards, etc.).
- Electrical inspection (switch, cord, plugs, etc.).
- Testing to assure proper mechanical and electrical operation.

Labels should also be replaced if worn or difficult to read. Contact NFE for replacement labels.

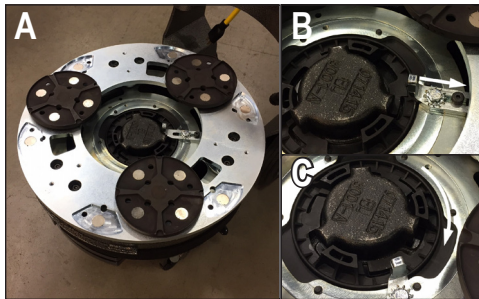

FIG. 2

REMOVING TOOLING ASSEMBLY

1. Disconnect machine from power; disconnect the handle cord from the motor cord (Figure 1); remove the safety key.
2. Remove the top weights by removing the cotter pins that hold them in place.
3. If the dust skirt has not already been removed, ensure the (4) skirt retainers are in position to keep the dust skirt in place (sticking outward).
4. Flip base assembly over 180° until it rests on the two handles (Figure 2A).
5. Loosen the hex head cap bolt securing the locking tab and slide the locking tab back (Figure 2B). Rotate the tooling assembly clockwise to stop (Figure 2C).
6. Lift off tooling assembly.
7. To reinstall the tooling assembly, reverse the above steps.

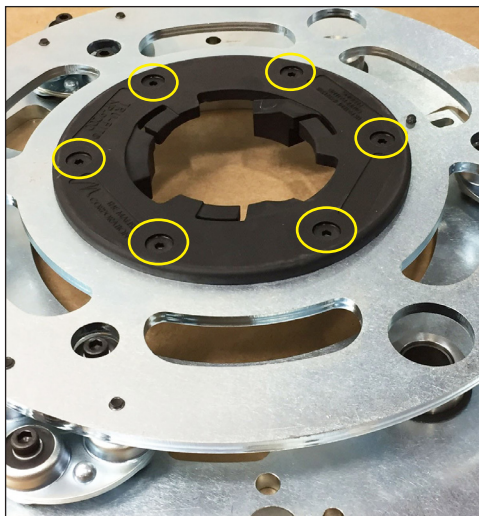

FIG. 3

REPLACING NYLON CLUTCH

1. Follow *Removing Tooling Assembly* procedure to gain access to the nylon clutch.
2. Remove the (6) screws (P/N 74620) using a 4mm Allen wrench (see Figure 3).
3. Discard the damaged clutch.
4. Orient the nylon clutch (P/N 403978) so that any one of the (3) clutch fingers (F) lines up with the locking tab (T). See Figure 4.
5. Tighten the (6) screws to 25 ft.lbs. using a 4mm Allen wrench.

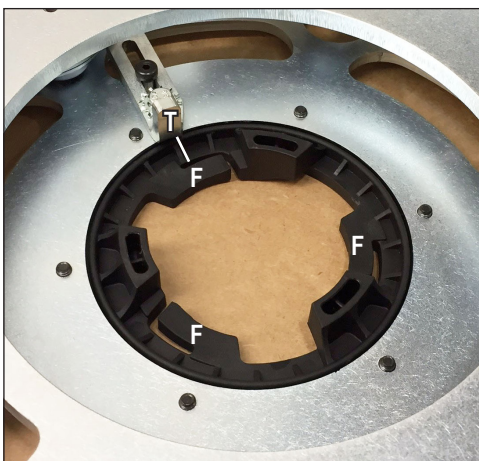

FIG. 4



CAUTION: MAKE SURE THE ORIENTATION OF THE NYLON CLUTCH IS CORRECT! OTHERWISE THE TOOLING ASSEMBLY WILL NOT BE PROPERLY SECURED IN THE BASE.

REPLACING SATELLITE BEARING ASSEMBLIES

1. Follow *Removing Tooling Assembly* procedure to gain access to the satellite bearing assemblies.
2. Remove the retaining ring using retaining ring pliers.
3. Remove the bearing assembly from the base plate (Figure 5).
4. Insert the new bearing assembly (P/N 404081) into the base plate.
5. Install the retaining ring using retaining ring pliers (Figures 5 and 6).

REPLACING MORFLEX COUPLERS

1. Follow *Removing Tooling Assembly* procedure to gain access to the Morflex couplers.
2. Remove the (4) retaining screws (two on each side of the coupler). See Figure 7.

Note: You may need to loosen the retaining screws of the other Morflex couplers to allow removal of the damaged coupler. See *Tooling Assembly diagram*.

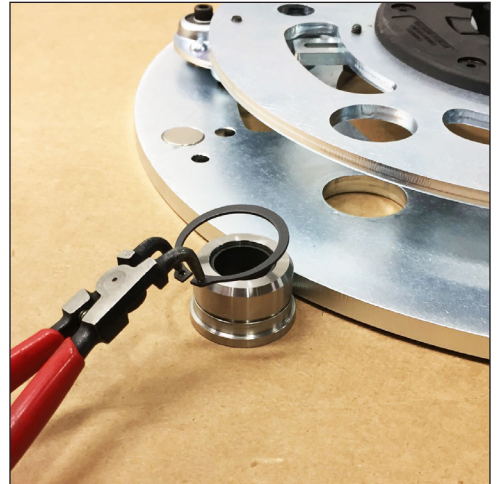

FIG. 5

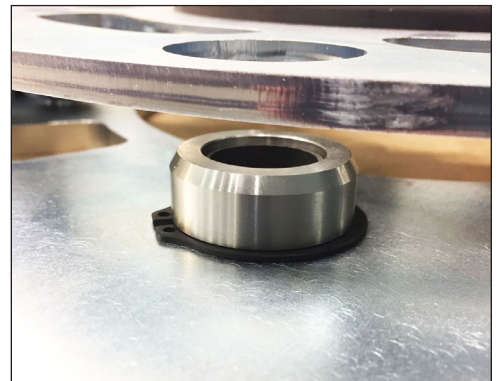

FIG. 6

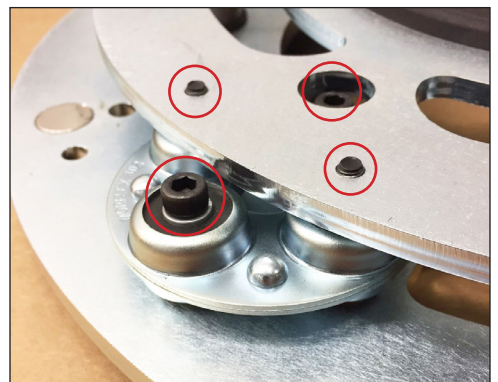

FIG. 7

Maintenance



FIG. 8

REPLACING MOTOR BRUSHES

Next to the dual speed toggle on the motor is a light (Figure 8). If the light is on, the brushes need to be replaced. To replace brushes, complete the following steps:

1. Disconnect machine from power; remove the safety key.
2. Remove (3) bolts on cover (Figure 9); remove cover. **Note:** Do not remove the commutator end bracket. Brushes can be installed through the openings in the bracket.
3. Remove (4) screws inside motor next to each brush (Figure 10).
4. Pull back spring and remove brush (Figure 11).
5. Replace brushes (wires should be on the top half of the brush). **Note:** Brush shunt should be out of the way of the spring or brush holder.

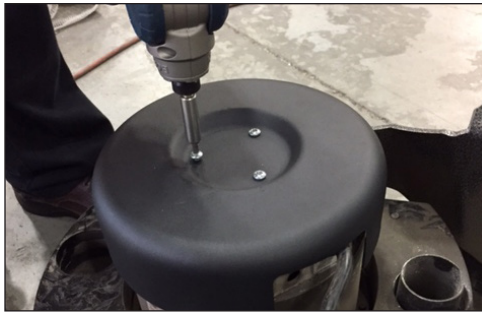
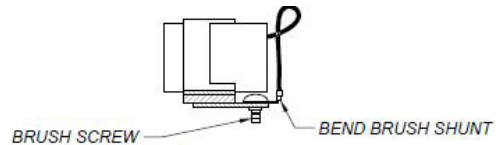

FIG. 9



6. Repeat for remaining brushes.

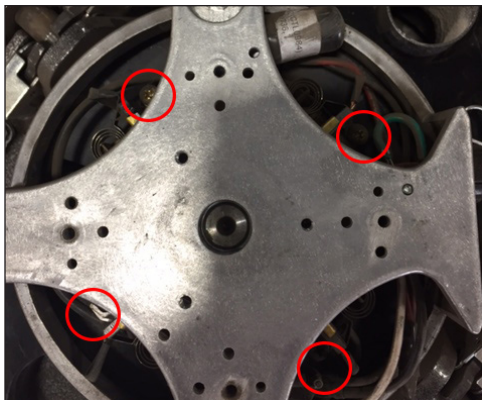

FIG. 10

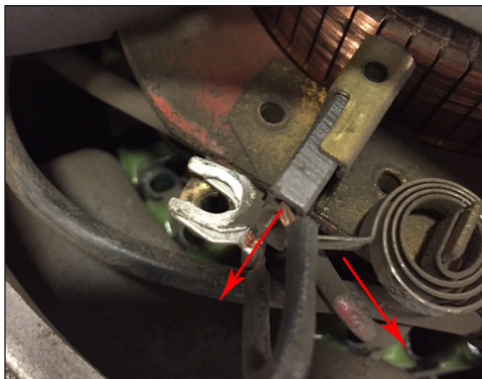

FIG. 11

LIGHT

If the light won't turn on, ensure that the plug is connected at the bottom of the control box (Figure 12).

ACCESSING ELECTRICAL COMPONENTS

1. Disconnect machine from power; remove the safety key.
2. Unplug light located under the cover (Figure 11).
3. Remove (4) bolts – 2 on the side, 2 on the top – on cover.
4. Remove cover.
5. Remove (4) screws – 2 on the top near controls, 2 on the bottom – from control panel.
6. Remove control panel to gain access to electrical components (Figure 13).



FIG. 12

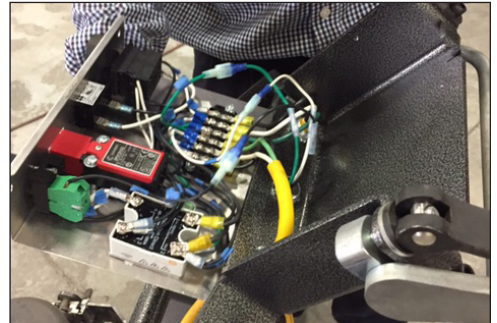
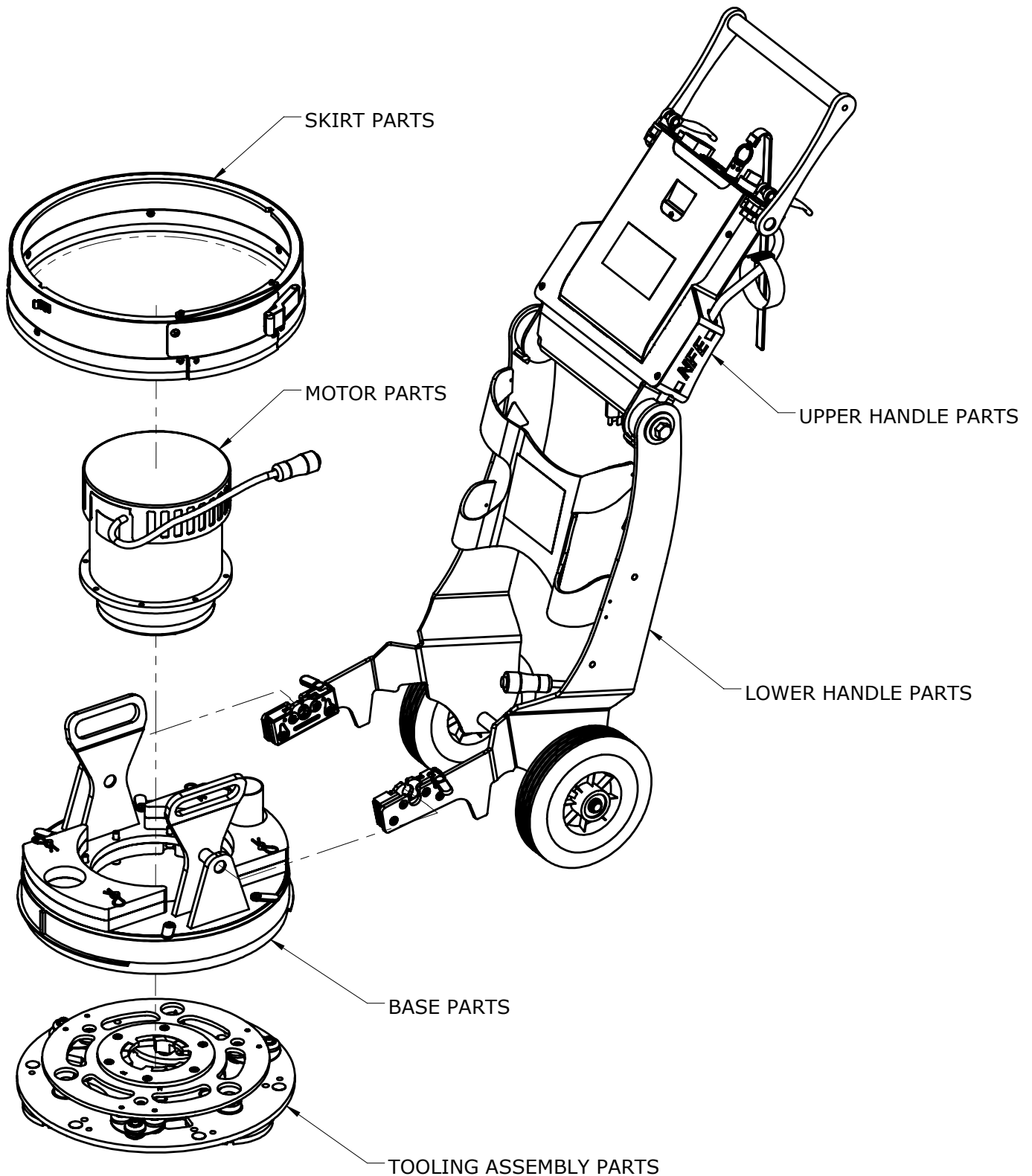

FIG. 13

Parts List and Diagrams

OVERALL MACHINE



Parts List and Diagrams

BASE ASSEMBLY

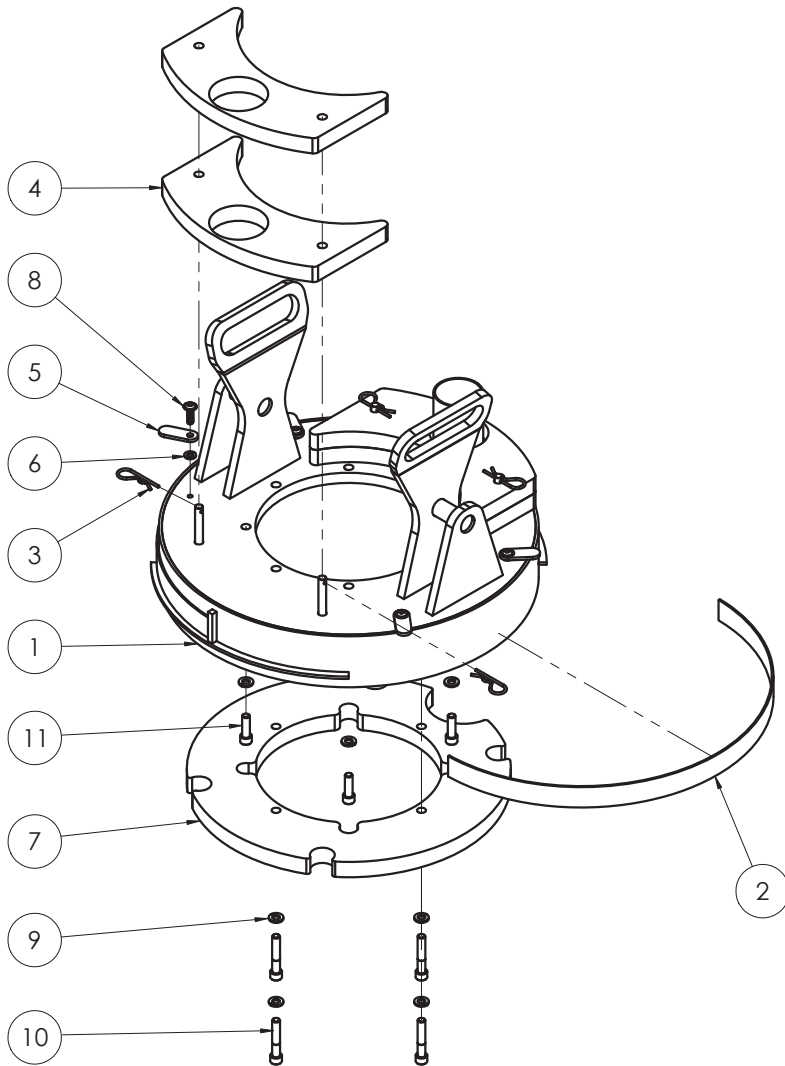

ITEM NO.	PART NUMBER	DESCRIPTION	QTY.
1	402798-SV	Shroud, Grinder, 15 inch, Imperial	1
2	402756	Seal, Felt, 1.5 x .078"	4'
3	402764	Pin, Weight, Hold Down	4
4	403004	Weight, Grinder, Imperial Gearbox	4
5	403165	Retainer, Skirt	4
6	403140	Washer, Flat, M6	4
7	403169	Weight, Ring, 12.5 x 3/4	1
8	403171	Screw, Flanged Socket Head Cap, M6-1.0 x 20mm	4
9	73303	Washer, Split Lock 5/16	8
10	73348	Screw, Socket Head Cap 5/16-18x1-3/4	4
11	73311	Screw, Socket Head Cap, 5/16-18 x 1	4

Parts List and Diagrams

402757 TOOLING ASSEMBLY

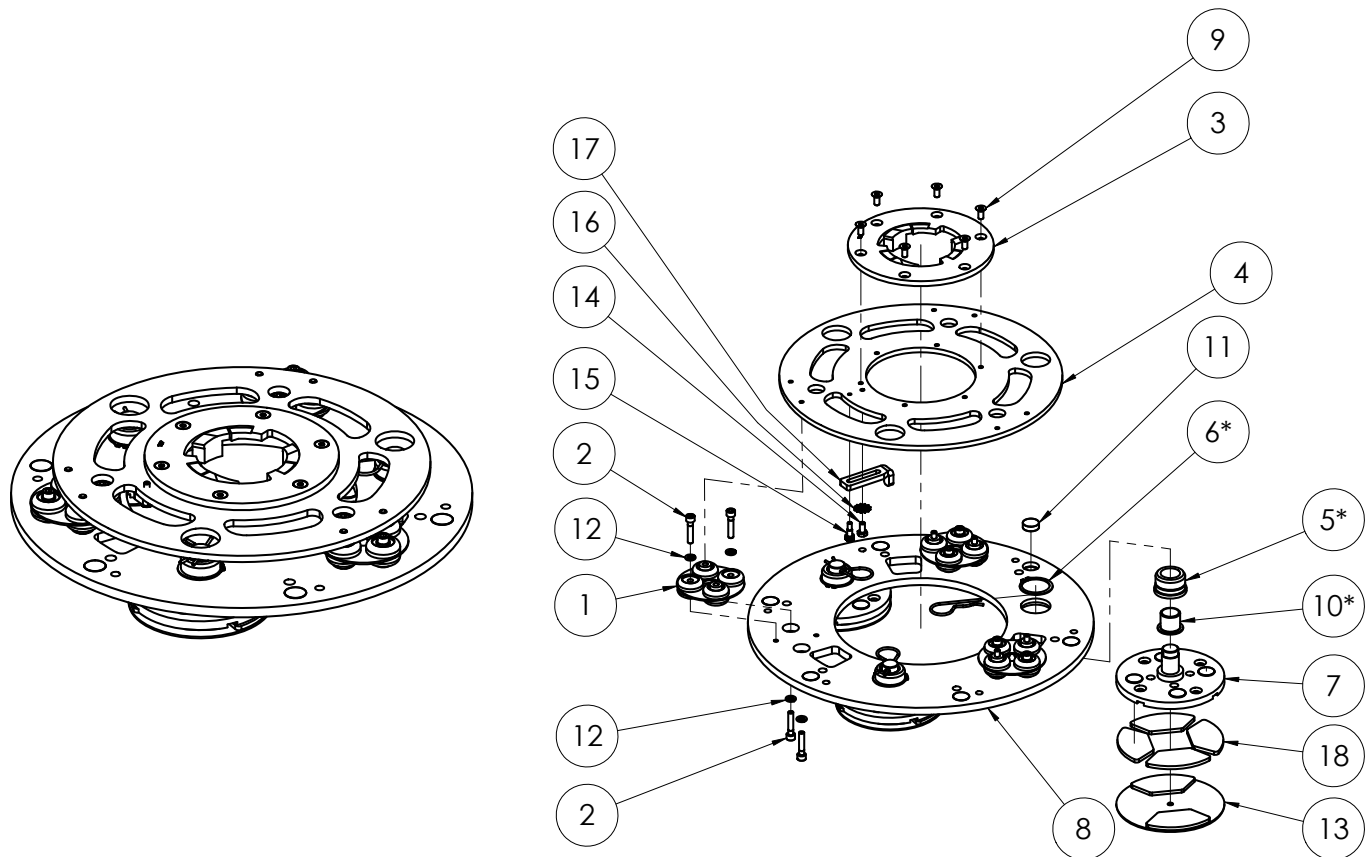

ITEM NO.	PART NUMBER	DESCRIPTION	QTY.
1	402781	Coupler, Morflex, 3.625"	3
2	402796	Screw, Socket Head Cap, M6-1.0 x 35mm	12
3	403978	Clutch, 5", Nylon	1
4	403979	Plate, Tooling, Clutch	1
5*	403994	Insert, Bearing, Flange, Tooling Plate	3
6*	404019	Clip, Retaining, Axial, 1.375	3
7	404021	Assembly, Satellite, Magnetic, 5" x 1.81"	3
8	404022	Ring, Tooling, Base	1
9	74620	Screw, Flat Head Socket Cap, M6-1.0 x 14	6
10*	404028	Bearing, Flange, Plain, 20 x 21.5mm	3
11	404084	Magnet, .75 Round, .250 Thick, N38SH	6
12	74619	Washer, Lock, M6	12
13	9245	Velcro Plate Adaptor	3
14	74630	Bolt, Hex Head Cap M6-12 8.8	1
15	404026	Bolt, Shoulder, 6mm x 8, M5-0.8	1
16	404027	Washer, Internal/External, 1/4"	1
17	403992	Retainer, Clutch, Slider	1
18	9500	Blank, Quick Change	12



*SOLD AS PART OF ASSEMBLED REPLACEMENT KIT# 404081

Parts List and Diagrams

403231 SKIRT ASSEMBLY

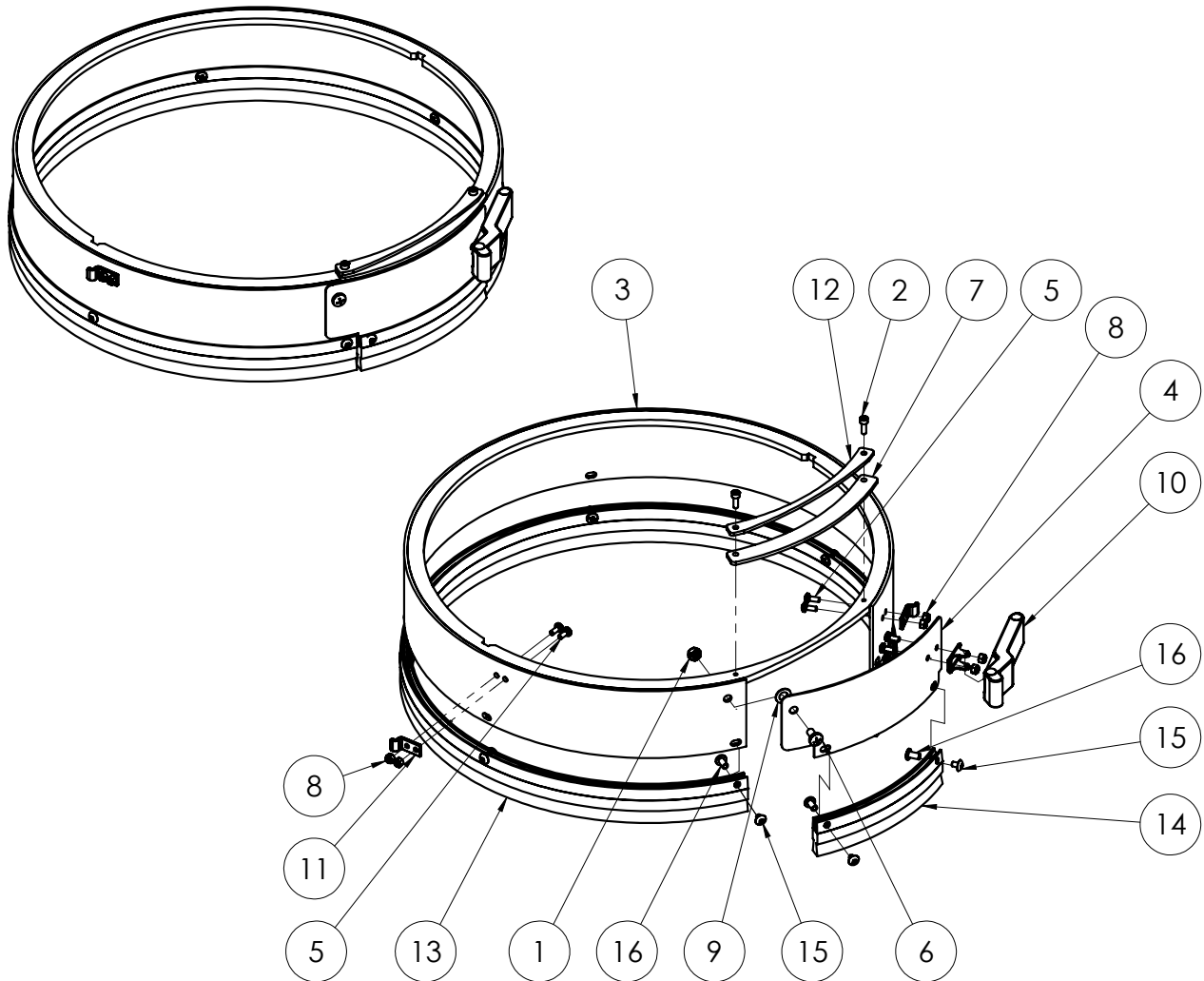

ITEM NO.	PART NUMBER	DESCRIPTION	QTY.
1	401516	Nut, M6-1.0 Nylock	1
2	401653	Screw, Socket Head Cap, M4-0.7 x 12	2
3	402705	Skirt, Floating, Edge Grinding, 16 inch	1
4	402755	Shield, Dust, Edge, Grinding	1
5	403075	Screw, Pan Head Machine, M4X0.7 - 10mm	6
6	403077	Screw, Pan Head Machine, M6X1.0 - 12mm	1
7	403168	Seal, Edge Grinding, Rubber	1
8	403170	Nut, M4-0.7, Nylock	6
9	403174	Washer, Flat, 1/4 x .031, Fiber	1
10	403180	Strap, Elastic	1
11	403186	Bracket, Elastic Strap	1
12	403193	Clamp, Rubber Edge Seal	1
13	403928	Brush, Strip, Skirt, 46"	1
14	403929	Brush, Strip, Skirt, 6"	1
15	403930	Screw, Oval Philips Head Machine Screw 8-32x1/4	8
16	403931	Screw, Truss Head Binding Post 13/64x3/8x8-32	8

Parts List and Diagrams

MOTOR

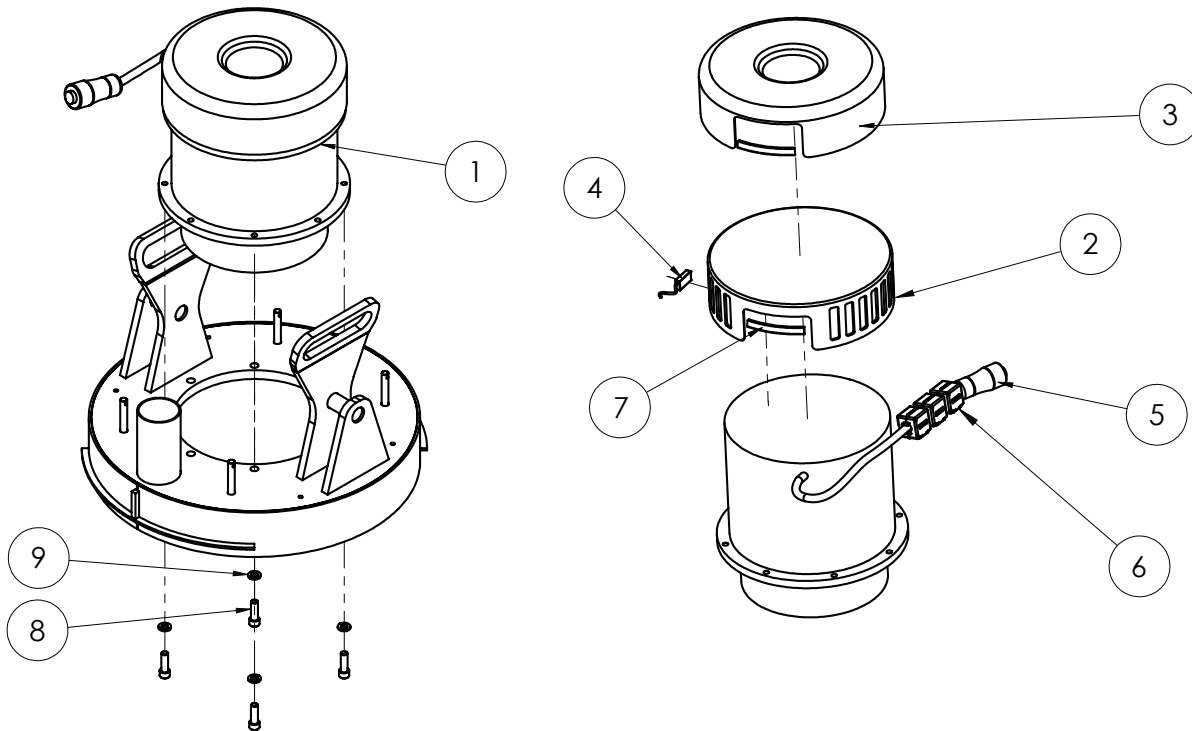

ITEM NO.	HELIX-10XXXX HELIX-12XXXX HELIX-23XXXX	HELIX-28XXXX	HELIX- 20XXXX	HELIX-11XXXX HELIX-13XXXX HELIX-15XXXX HELIX-26XXXX HELIX-27XXXX	DESCRIPTION	QTY.
1*	403152		403152		Assembly, Motor/Gearbox, 120 Volt	1
		403811		403902	Assembly, Motor/Gearbox, 100V, Japan	
					Assembly, Motor/Gearbox. 230 Volt	
2	403154	403154	403154	403154	Cover, Vented	1
3	403155	403155	403155	403155	Cover, Drip Proof	1
4	403319	403319	403319	403319	Brush, DC Motor	4
5	402801	402801	402801	402801	Plug, Male, 16A, 400V, 4C, Circular, Screw Terminal	1
6	N/A	403818	N/A	N/A	Ferrite, Solid, 50 Ohm, 1.047" OD x .504 ID	3
7	403382	403382	403382	403382	Trim, Edge, .23"W x .36"H	2.75"
8	73311	73311	73311	73311	Screw, Socket Head Cap, 5/16-18 x 1	4
9	73303	73303	73303	73303	Washer, Split Lock 5/16	4

*NOTE: Item 1 includes Items 2-7. Items 2-7 are also available separately.

Parts List and Diagrams

LOWER HANDLE ASSEMBLY

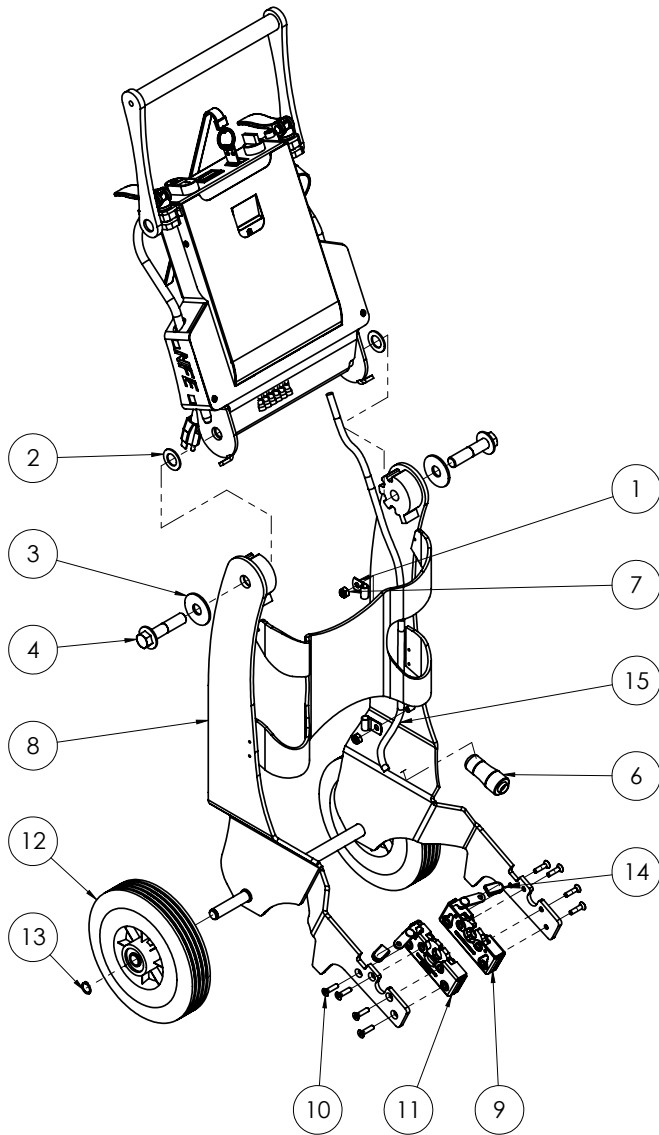

ITEM NO.	HELIX-10XXXX HELIX-12XXXX HELIX-23XXXX	HELIX-11XXXX HELIX-13XXXX HELIX-15XXXX HELIX-20XXXX HELIX-26XXXX HELIX-27XXXX HELIX-28XXXX	DESCRIPTION	QTY.
1	72873	72873	3/8 Cable Clamp	2
2	402721	402721	Washer, Nylon, Mil-spec, 3/4 inch ID x .03 inch thk	2
3	402725	402725	Washer, M16 x 50mm OD, Clear Zinc	2
4	402726	402726	Screw, Flange Head, M16x2.0 - 70mm	2
6	402802	402802	Receptacle, Female, 16A, 400V, 4C, Circular, Screw Terminal	1
7	401509	401509	Nut, M8-1.25 Nylock	2
8	402707-SV	402707-SV	Weldment, Lower Handle, Pivoting	1
9	402737	402737	Latch, Bear Jaw, Left	1
10	403076	403076	Screw, Flat Head Socket Head Cap, M6x1.0 - 25	8
11	402736	402736	Latch, Bear Jaw, Right	1
12	550-29	550-29	Wheel, 2-1/2 Center	2
13	402734	402734	Ring, Retaining, External, 5/8inch	2
14	402786	402786	Cap, Latch, Black Vinyl	2
15	72555		Cord, Power, SJEOW, 12/3, Yellow	3'
		72556	Cord, Power, H05VV-F, 2.5mm/3, Black	

Parts List and Diagrams

UPPER HANDLE ASSEMBLY

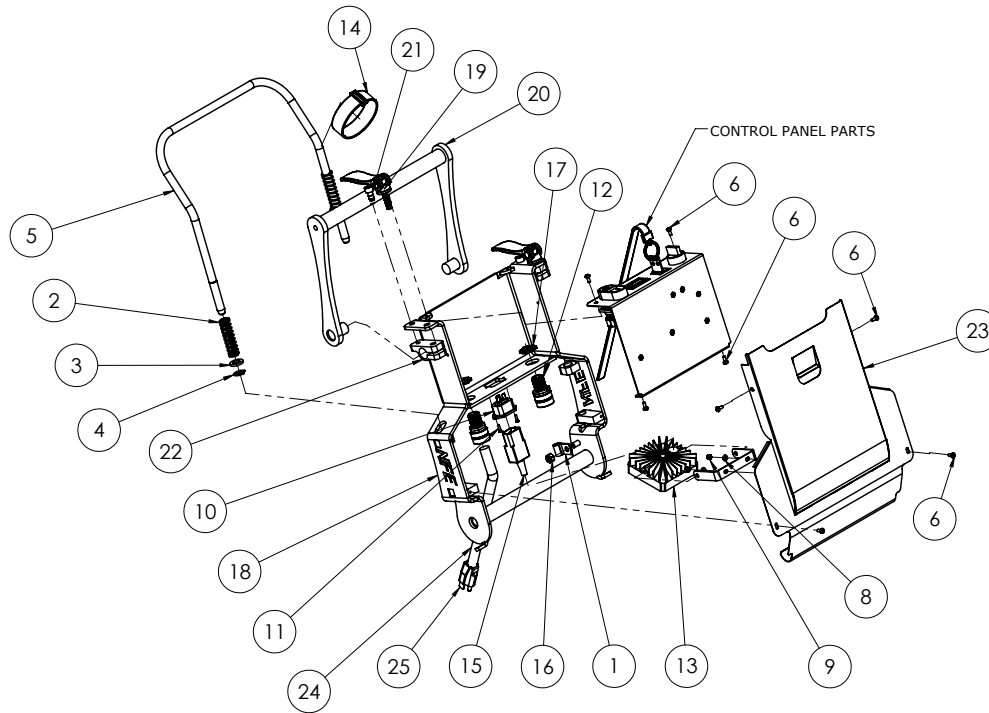

ITEM NO.	HELIX-10XXXX HELIX-12XXXX HELIX-23XXXX	HELIX-28XXXX	HELIX- 20XXXX	HELIX-11XXXX HELIX-13XXXX HELIX-15XXXX HELIX-26XXXX HELIX-27XXXX	DESCRIPTION	QTY.
1	72873	72873	72873	72873	3/8 Cable Clamp	1
2	402722	402722	402722	402722	Spring, .656"OD x 3"L x .062"W	2
3	402723	402723	402723	402723	Washer, Compression Retainer, 1/2" ID x 7/8" OD	2
4	80084	80084	80084	80084	E-Clip, 1/2" shaft	2
5	402724	402724	402724	402724	Handle, Pivot Control	1
6	403075	403075	403075	403075	Screw, Pan Head Machine, M4X0.7 - 10mm	8
8	401326	401326	401326	401326	WASHER, FLAT, M4	2
9	403170	403170	403170	403170	Nut, M4-0.7, Nylock	2
10	403176	403176	403176	403176	Receptacle, Panel Mount, IEC C-13, 250V, 15A	1
11	403187	403187	403187	403187	Screw, Flathead Machine, M3-0.5 x 12mm	2
12	72804	72804	72804	72804	Strain Relief, Straight, 1/2"	2
13	403157	403157	403157	403157	Light, LED, 12 Watt (Bracket included)	1
14	402797	402797	402797	402797	Cinch Strap, Velcro, 1" x 12"	1
15	403177	403177	403177	403177	Plug, IEC-14, 250V, 10A	1
16	401509	401509	401509	401509	Nut, M8-1.25 Nylock	1
17	73401	73401	73401	73401	Nut, Strain Relief, Steel, 1/2"	2
18	402716-SV	402716-SV	402716-SV	402716-SV	Weldment, Upper Handle, Pivoting	1
19	402729	402729	402729	402729	Lock, Cam, M8x1.25	2
20	402730	402730	402730	402730	Handle, Dipped	1
21	403384	403384	403384	403384	Screw, Socket Head Cap, M8x1.25 - 16mm, Adhesive Patch	2
22	403179	403179	403179	403179	Clamp, Handle bar, 3/4 ID	2

NOTE: 6X 403185 (TERMINAL, RING, 12-10GA, #6) ARE NOT SHOWN

ITEM NO.	HELIX-10XXXX HELIX-23XXXX	HELIX-12XXXX	HELIX-28XXXX	HELIX-20XXXX	HELIX-11XXXX HELIX-13XXXX HELIX-26XXXX	HELIX-15XXXX	HELIX-27XXXX	DESCRIPTION	QTY.
23	402727-BLK	402727-G	403804-BLK	402727-BLK	403834-BLK	403834-O	403834-BLK	Cover, Handle, Upper, Pivoting	1
24	6280-168	6280-168	72565	72565	72565	72565	402839	Cord, Power	N/A
25			403719	401486	401438	401438		Plug, Electrical	1

Parts List and Diagrams

HANDLE ASSEMBLY (INTERNATIONAL ONLY)

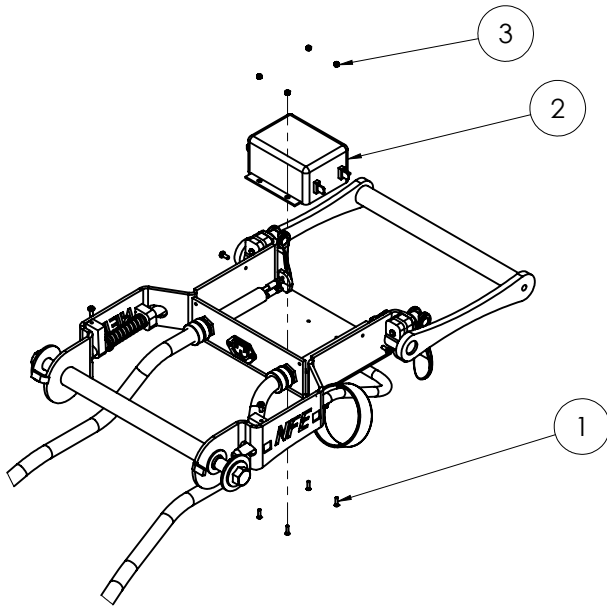

ITEM NO.	HELIX-11XXXX HELIX-13XXXX HELIX-15XXXX HELIX-26XXXX HELIX-27XXXX HELIX-28XXXX	DESCRIPTION	QTY.
1	403187	Screw, Flathead Machine, M3-0.5 x 12mm	6
2	403802	Filter, Electrical, 250V	1
3	403115	Nut, M3-0.5, Nylock	4
4*	72812	Terminal, QC, Female, Yellow Nylon, .250, 10-12AWG	5
5*	403150	Terminal, QC, Piggyback, Yellow Nylon, .250, 10-12AWG	1

NOTE: HELIX-10XXXX, HELIX-12XXXX, HELIX-20XXXX, HELIX-23XXXX WILL NOT NEED THESE PARTS

*NOT SHOWN

Parts List and Diagrams

CONTROL PANEL - 100/110/120V

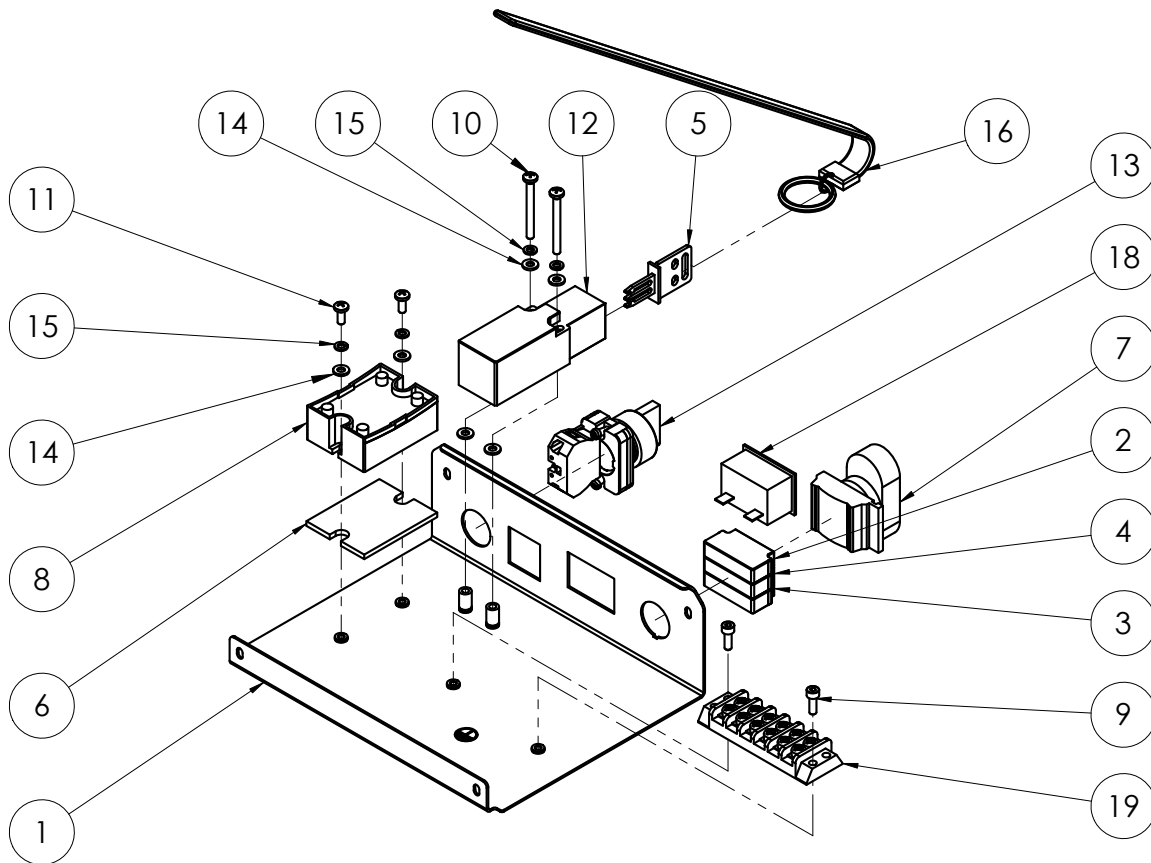

ITEM NO.	HELIX-10XXXX HELIX-12XXXX HELIX-20XXXX HELIX-23XXXX	HELIX-28XXXX	DESCRIPTION	QTY.
1	402768	403800	Cover, Electric Box, Pivoting Handle	1
2	403879	403879	Contact, NC, Pushbutton, BF	1
3	403880	403880	Contact, NO, Pushbutton, BF	1
4	403881	403881	Block, LED Lamp, Green, 110VAC, BF	1
5	402774	402774	Key, Safety Switch	1
6	402784	402784	Plate, Heat Sink, Relay	1
7	403877	403877	Pushbutton, On/Off, Light, BF	1
8	402772	402772	Relay, Solid State, 90-280VAC, 75A, SPST	1
9	401653	401653	SHCS, M4-0.7 x 12	2
10	402785	402785	Screw, PPH, M4-0.7 x 40mm, Zinc	2
11	403075	403075	Screw, Pan Head Machine, M4X0.7 - 10mm	2
12	402773	402773	Switch, Safety, 10A	1
13	403158	403158	Switch, Selector, Two position	1
14	401326	401326	Washer, Flat, M4	6
15	402787	402787	Washer, Lock, #8	4
16	403044	403044	Wrap, Wrist, Safety	1
18	403253	403253	Meter, Hour, Digital, 90-64VAC, 10-300VDC, 50/60Hz, Snap-on	1
19	403316	403316	Harness, Wire, M2000	1

NOTE: WIRES ARE NOT SHOWN FOR 403316

Parts List and Diagrams

CONTROL PANEL - 230V

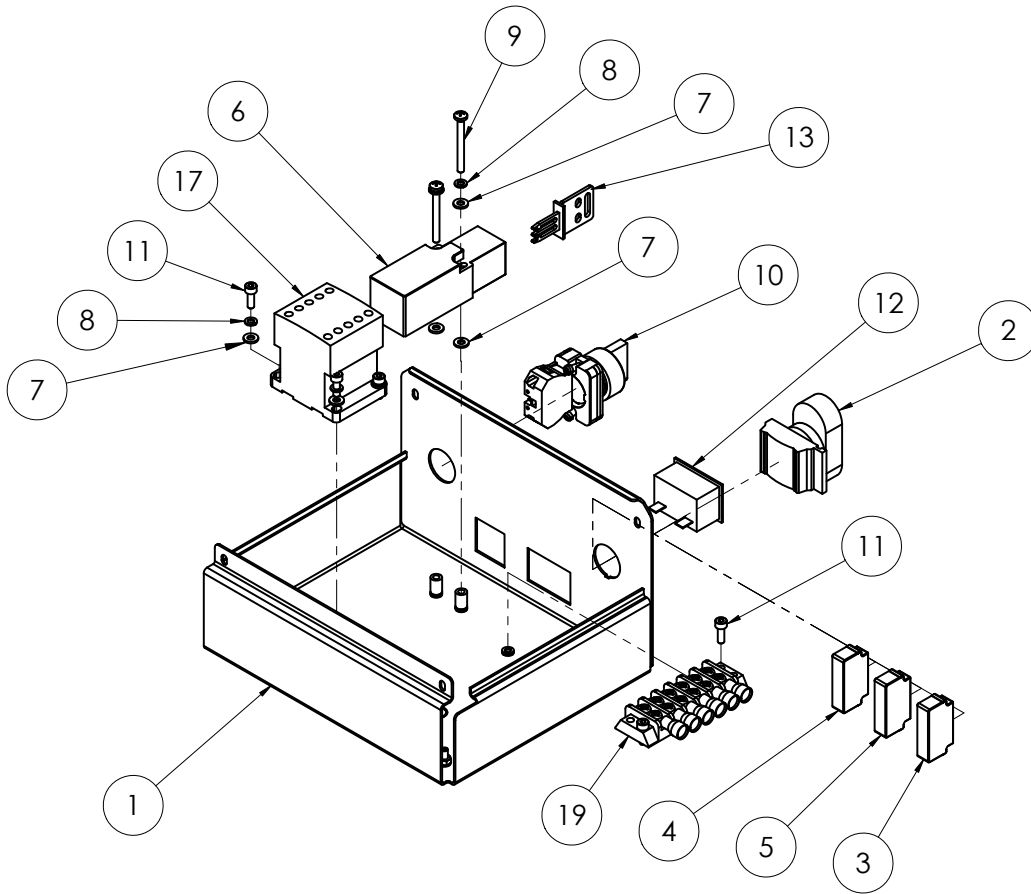

ITEM NO.	HELIX-11XXXX HELIX-13XXXX HELIX-15XXXX HELIX-26XXXX HELIX-27XXXX	DESCRIPTION	QTY.
1	403829	Cover, Electric Box, Pivoting Handle, 2.17" Flange	1
2	403877	Pushbutton, On/Off, Light, BF	1
3	403879	Contact, NC, Pushbutton, BF	1
4	403880	Contact, NO, Pushbutton, BF	1
5	403878	Block, LED Lamp, Green, 220VAC, BF	1
6	402773	Switch, Safety, 10A	1
7	401326	Washer, Flat, M4	8
8	402787	Washer, Lock, #8	7
9	402785	Screw, PPH, M4-0.7 x 40mm, Zinc	2
10	403158	Switch, Selector, Two position	1
11	401653	SHCS, M4-0.7 x 12	6
12	403253	Meter, Hour, Digital, 90-64VAC, 10-300VDC, 50/60Hz, Snap-on	1
13	402774	Key, Safety Switch	1
15	403044	Wrap, Wrist, Safety	1
16	403185	Terminal, Ring, 12-10ga, #6	6
17	403828	Contactor, 230V, 50/60Hz, 12A, 3 Pole	1
19	403873	Harness, Wire, Helix, 2.17" Flange	1

NOTE: WIRES ARE NOT SHOWN FOR 403873

Parts List and Diagrams

LABELS

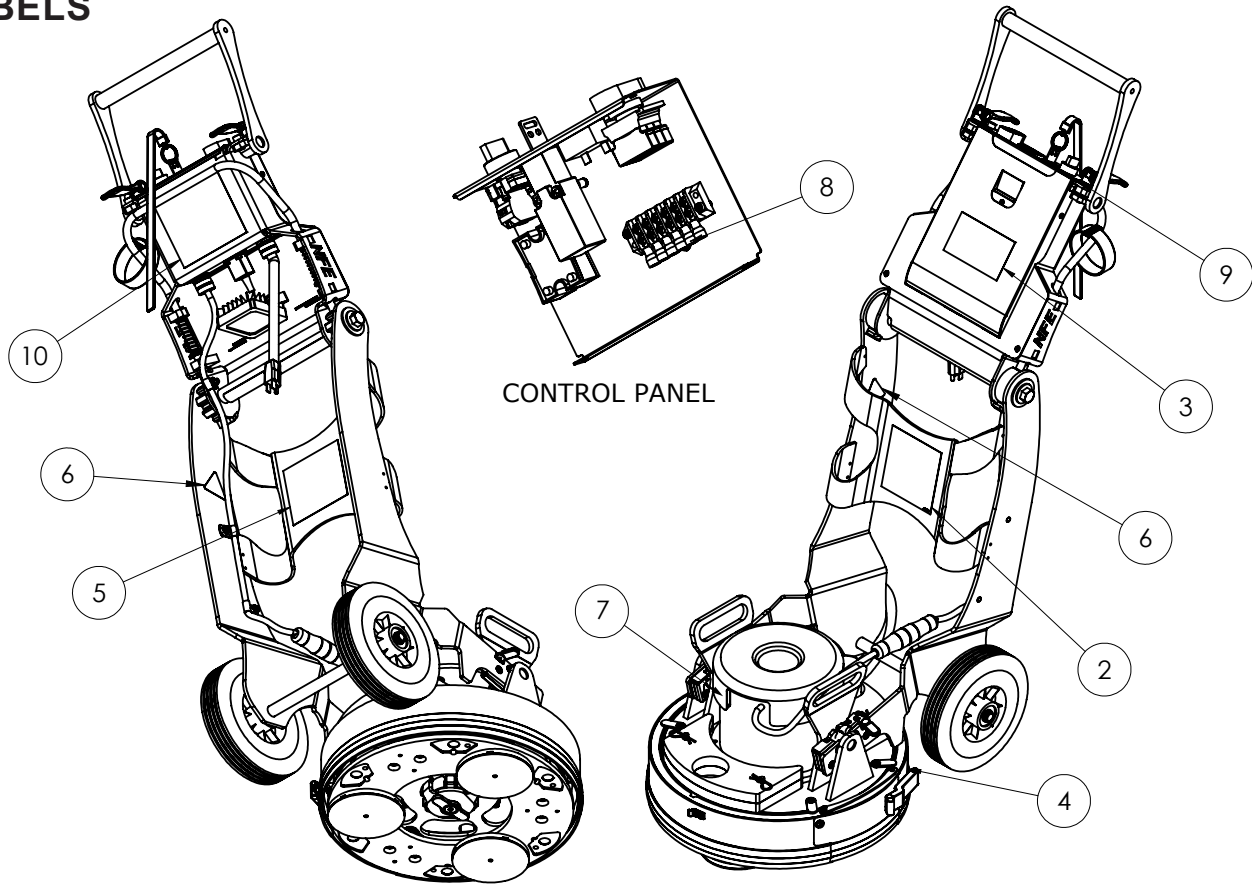

ITEM NO.	HELIX-XXXXXX	DESCRIPTION	QTY.
1*	403358-XX	Kit, Labels, Helix, [LANGUAGE]	1
2**	402463	Label, National Logo, 4.5 x 4.5	1
3**	403049	Label, Helix	1
4**	403060	Label, Entanglement Hazard	1
5**	403062	Label, Safety Guideline	1
6**	403065	Label, Pinch Point Hazard	2
7**	403649	Label, Motor Speed Change	1

*Kit includes Items 2-7. Suffix (-XX) denotes language: None=English; -FR=French; -NL=Dutch; -DE=German; -JA=Japanese.

**Item included in kit. Also available separately in English only.

ITEM NO.	HELIX-10XXXX HELIX-12XXXX HELIX-23XXXX	HELIX-20XXXX	HELIX-28XXXX	HELIX-11XXXX HELIX-13XXXX HELIX-15XXXX HELIX-26XXXX HELIX-27XXXX	DESCRIPTION	QTY.
8	403086	403086	403086	403086	Label, Ground	1
9	403066	403066			Label, Control Panel	1
			403831	403831	Label, Control Panel, International	
10	403061				Label, CE, Helix, 120V, 60Hz	1
		403904			Label, CE, Helix, 110V, 50Hz	
			403905-JA		Label, CE, Helix, 100V, 50Hz, Japanese	
				403903	Label, CE, Helix, 230V, 50Hz	

Parts List and Diagrams

WIRING DIAGRAM - 110/120V (HELIX-10XXXX, -12XXXX, -20XXXX, -23XXXX ONLY)

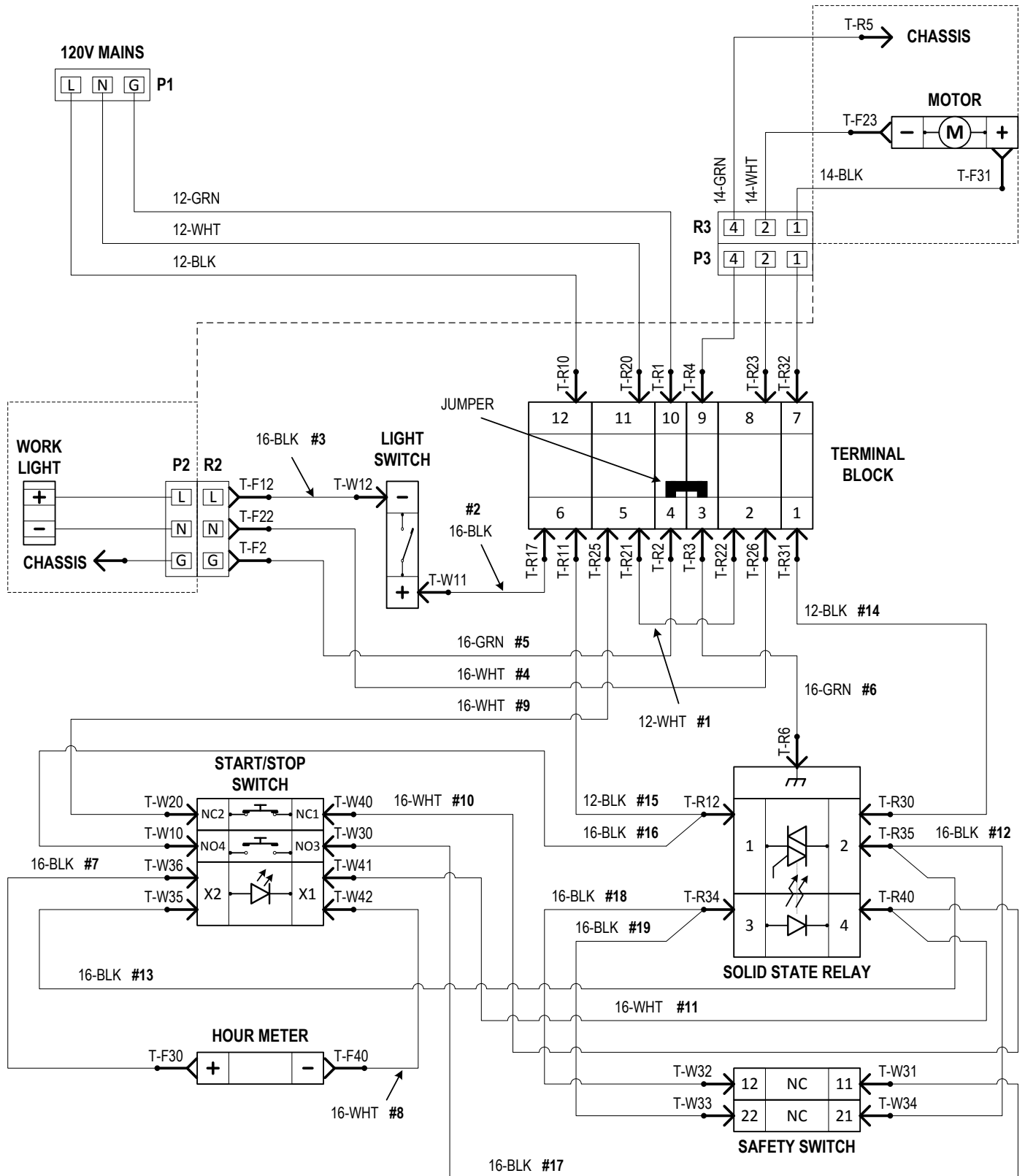

Parts List and Diagrams

WIRING DIAGRAM - 230V

(HELIX-11XXXX, -13XXXX, -15XXXX, -26XXXX, -27XXX ONLY)

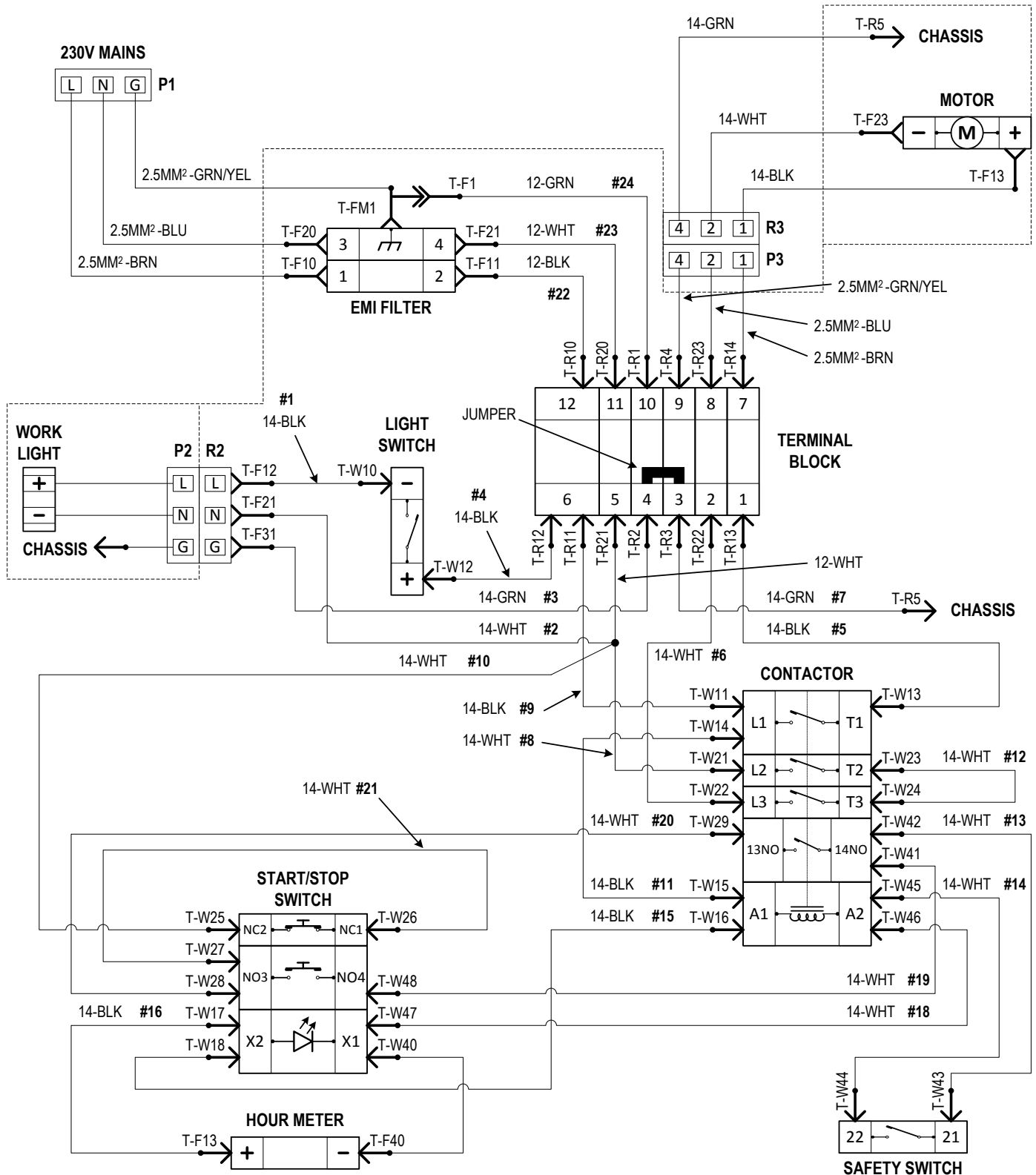

Parts List and Diagrams

WIRING DIAGRAM - 100V (HELIX-28XXXX ONLY)

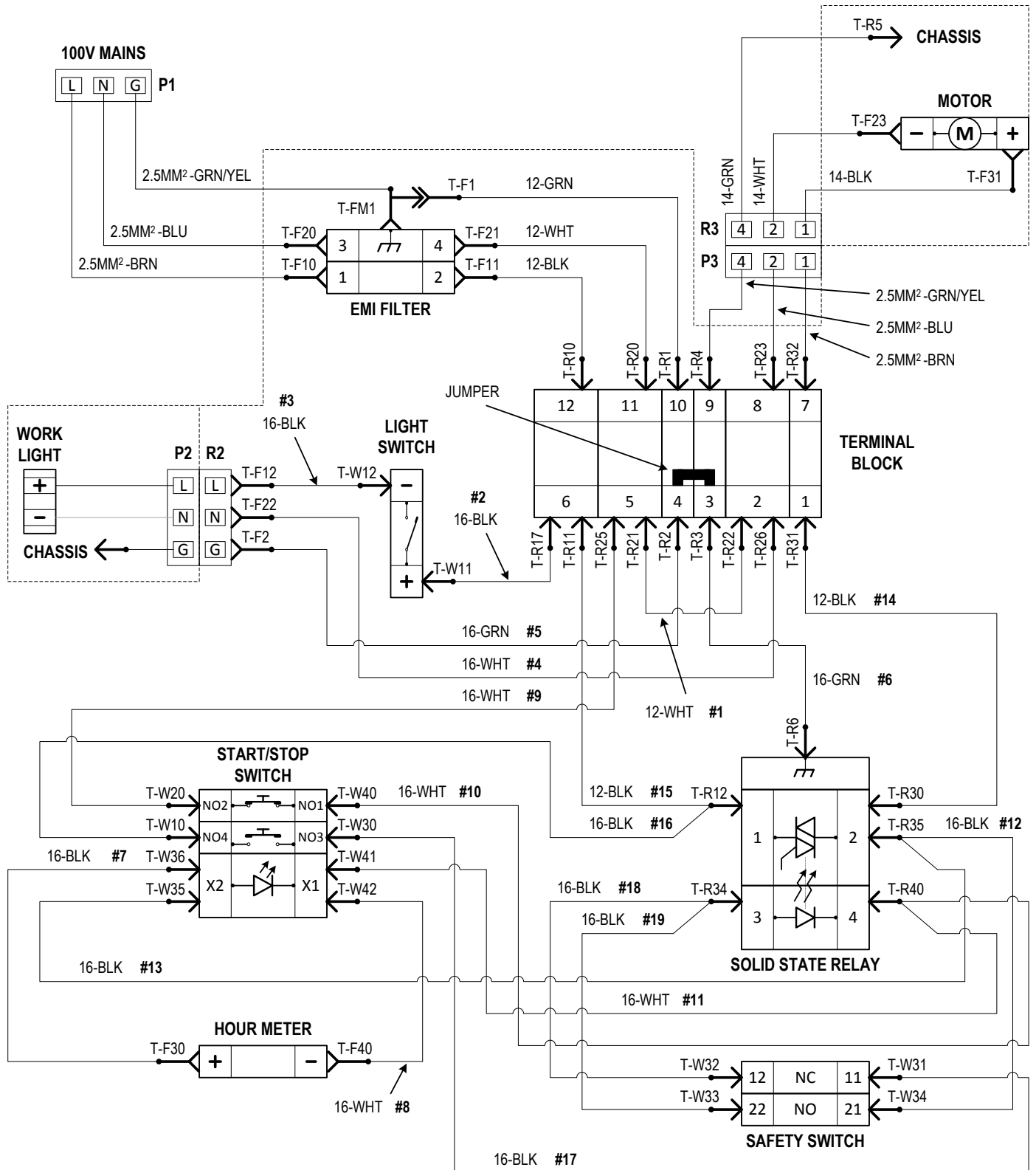

Warranty

National Flooring Equipment Inc. (referred to as "The Company") warrants that each new unit manufactured by The Company to be free from defects in materials and workmanship in normal use and service for a period of twelve (12) months from date of shipment from The Company to the end user. If shipment to end user is from a Distributor, The Company may honor warranty for up to 15 months from initial shipment from the Company if the end user can provide documentation of receipt date. Accessories or equipment furnished and installed on the product by the Company but manufactured by others, including but not limited to: engines, motors, electrical components, transmissions etc., shall carry the accessory manufacturers own warranty. Battery warranties are prorated over the warranty period. Customer is responsible for the inspection of equipment or parts upon delivery. **Freight damages are excluded from this warranty.**

The Company, at its determination of defect, will repair or replace any product or part deemed to be defective in material or workmanship within specified warranty time period. All product determinations and / or repairs will take place at The Company repair facility or at a certified warranty location designated by The Company. The Company will coordinate and be responsible for all freight expenses associated with valid warranty claims. Freight and shipping expenses associated with abuse or misuse will be back charged to the Distributor/Customer. The Company reserves the right to modify, alter or improve any part / parts without incurring any obligation to replace any part / parts previously sold without such modified, altered or improved part / parts. In no event shall the seller or manufacturer of the product be liable for special, incidental, or consequential damages, including loss of profits, whether or not caused by or resulting from the negligence of seller and / or the manufacturer of the product unless specifically provided herein. **This warranty shall not apply to any products or portions there of which have been subjected to abuse, misuse, improper installation or operation, lack of recommended maintenance, electrical failure or abnormal conditions, and to products which have been tampered with, altered, modified, repaired, reworked by anyone not approved or authorized by the Company or used in any manner inconsistent with the provisions of the above or any instructions or specifications provided with or for the product.** Any and all unauthorized onsite warranty work conducted by unauthorized personnel or any outside person(s), is not covered by The Company unless the work has been pre-authorized by a predetermined manufacturer representative. This warranty excludes wearable parts and/or consumables.

Defective or failed material or equipment shall be held at the purchaser's premises until authorization has been granted by The Company to return or dispose of defective products. Products returned to The Company for inspection must be returned with a manufacturer authorized Return Material Authorization (RMA), and must be packaged to The Company's specifications to avoid damage during shipment. Any unauthorized return of equipment will be declined at the dock by The Company. Any non-approved items returned with approved returned items are subject to rejection and will not be credited. Credit will be issued for material found to be defective upon The Company's inspection based on prices at time of purchase.

TO OBTAIN SERVICE CONTACT NATIONAL FLOORING EQUIPMENT, INC. TOLL FREE AT 800-245-0267 FOR A REPAIR AUTHORIZATION NUMBER. COD FREIGHT RETURNS WILL NOT BE ACCEPTED. FREIGHT COLLECT SHIPMENTS WILL NOT BE ACCEPTED. WARRANTY REPAIRS MUST BE ACCOMPANIED BY DATE OF PURCHASE RECEIPT AND A RETURN/ REPAIR AUTHORIZATION NUMBER.

RETURN/REPAIR AUTHORIZATION NUMBER: _____

MACHINE SERIAL NUMBER: _____



9250 Xylon Avenue N • Minneapolis, MN 55445 • U.S.A.
Toll-free 800-245-0267 • Phone 763-315-5300 • Fax 800-648-7124 • Fax 763-535-8255
Web Site: www.nationalequipment.com • E-Mail: info@nationalequipment.com